

D

C

B

A

Note:
 Avoid applying pressure on the centre
 of the lens during installation

DATE

001

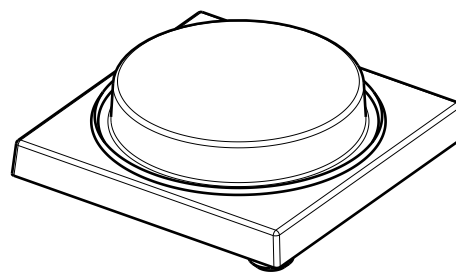
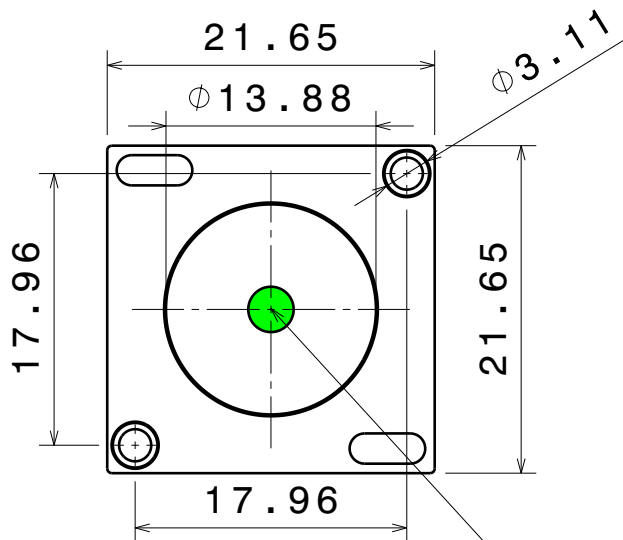

Isometric View
 Scale: 2:1

Bottom view
 Scale: 2:1

LED position

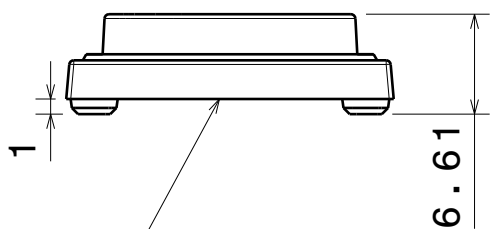

Front View
 Scale: 2:1

PCB top surface

LED position:
 The recommended tolerance
 in z-position is ± 0.1 mm

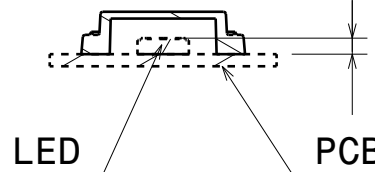

PART	TYPE	MATERIAL	COLOR / COATING
F17822_VIOLETTA-S	LENS	Silicone	Clear

MECHANICAL DRAWING

PRODUCT

VIOLETTA

LEDiL®

Plastic moulding general tolerances according to DIN 16901-130 and applies if not otherwise shown in the drawing. Silicone moulding general tolerances according to ISO 3302-1 Class M3 and applies if not otherwise shown in the drawing.

FIRST ANGLE PROJECTION:

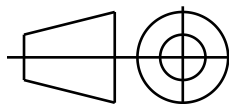

This drawing is the property of LEDiL Oy. It may not be copied or otherwise distributed without prior written permission from LEDiL Oy.

SCALE 2:1

WEIGHT 1.3g

A4 SHEET 1/1

D

A